

## S-120.NGT.M2

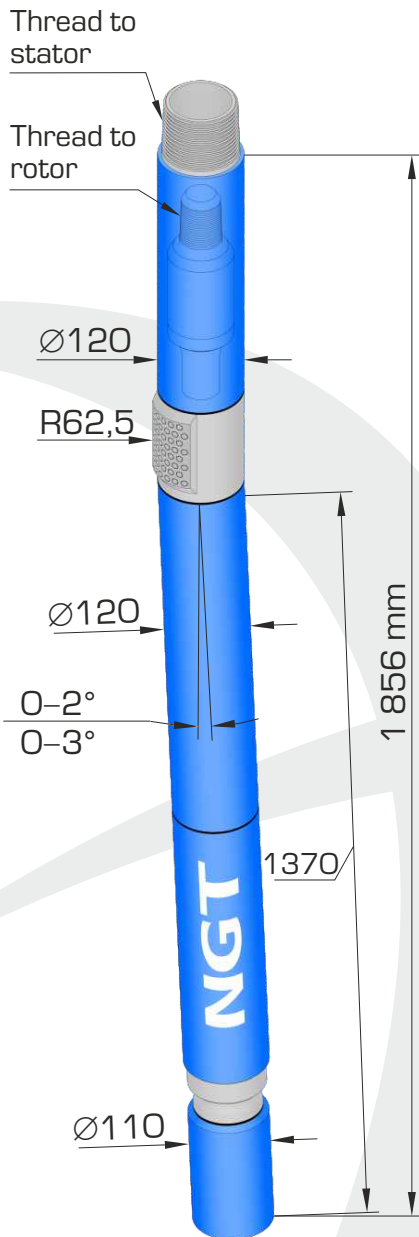

Bearing section S-120.NGT.M2 is a new short bearing section featuring enhanced operation life.

The bearing section is used in PDM power sections of 120 – 127 mm dia. and for:

- drilling of oil and gas wells;
- well reconstruction by sidetracking with rock and PDC bits, including bicentric ones, with the diameter of 132 – 165.1 mm;
- well workover.

Axial bearing of bearing section is a multi-row thrust ball bearing with toroidal raceways, radial bearings of bearing section are steel sleeves, having the friction surfaces reinforced with hard-alloy plates.

The bearing section is furnished with drive shaft with two joints to connect to the power section rotor. The bearing section design has adjustable bent sub. The adjustment range is from 0° up to 2° or from 0° up to 3°.

Meeting customers' requirements, the bearing section can be produced with the connecting threads for specific power section.

Top sub (safety sub) is available with the bearing section to connect the power section to drill pipes.

### Technical specifications

Housing OD, mm	120
Bearing section length, mm	1 856
Bearing section length to curvature plane, mm	1 370
Range of angle adjuster change, degree	0–2 или 0–3
Connecting thread to bit	3 1/2 Reg
Torque transmitted, max. kN*m	6,0
Tolerance of axial loading, kN	100
Overhaul period, hour	200